

SERIES 26

100A

Specification

Technical Data

Temperature range	-55°C to +74°C
Max. Altitude rating	50.000 ft
Protection	IEC 60529 & DIN 40050-9, IP67 (0,2 bar; 1min) & IP6K9K
Shock	30G - 11msec VG 95210, MIL-STD-202, Test method 213, Half-sine, 11 msec / 50 G
Vibration	10G VG 95210, MIL-STD-202, Test method 213, Test condition C / 10 G
Acceleration	15G
Thread sizes	M3.5 = 1.1-1.2Nm M4 = 2.0-2.2Nm M8 = 12-13Nm M10 = 15-20Nm
Wire section	min. 25mm ² / 0.039 sq.inch / AWG 3
Mounting position	optional

Electrical Characteristics

Rated contact load (12 & 24 / 28VDC)

Min. Insulation Resistance	100MΩ	Resistive load	50.000 cycles - 100A
After llve or environmental	50MΩ	Mechanical Life	100.000 cycles - 25A
Dielectric withstanding voltage	1050VAC / 1min at 50Hz		
Max. Contact drop, initial	150mV		
Contact drop after life test	175mV		
Continuous current	100A		
Overload	1000A - 1sec / 500A - 20sec		
Rupture current	1000A		
Auxiliary contacts	Continuous current 2A / Make and Brake 6A		

Coil Data

	12VDC	24 / 28 VDC
Voltage range	10-15VDC	18-32VDC
Nominal voltage	12VDC	24/28VDC
Pick up voltage max.	10VDC	18VDC
Drop out voltage	≤ 4VDC	≤ 6VDC
Pull in coil resistance	1,4Ω ± 20%	3,6Ω ± 20%
Pull in current max.	10A - 20msec	6/8A - 20msec
Coil resistance	40Ω ± 10%	145Ω ± 10%
Coil current max.	0,35A	0,20 / 0,25A

Operating times

NO Contact

Operate	max. 25msec
Bounce	max. 5msec
Release with suppression	max. 80msec
Release without suppression	max. 15msec

Operating times

NC Contact

Break time	max. 10msec
Make time with suppression	max. 60msec
Make time without suppression	max. 40msec

Available Types

	Type Ordering key	Contact		UNC threads	Reversed polarity	Side mounting	Side mount. with inserts	Suppression	Polarity protection	Auxiliary contact	Weight kg / pound
		NO	NC								
12V	26.60.21*	x				x					0.44 / 0.97
	26.60.25	x				x		x			0.44 / 0.97
	26.60.275	x				x		x		x	0.46 / 1.01
24V / 28V	26.60.01*	x				x					0.44 / 0.97
	26.60.04	x				x		x	x		0.45 / 0.99
	26.60.05	x				x		x			0.44 / 0.97
	26.60.15	x			x	x		x			0.44 / 0.97
	26.60.17	x				x		x			0.44 / 0.97
	26.60.75	x				x		x		x	0.46 / 1.01
	26.63.01		x			x		x	x		0.45 / 0.99
	26.63.02		x			x		x			0.44 / 0.97
	26.63.03*		x			x					0.44 / 0.97
	26.64.01		x	x		x		x	x		0.45 / 0.99
	26.64.02		x	x		x		x			0.44 / 0.97
	26.64.03		x	x		x					0.44 / 0.97

Other types and customer specified types upon request / also available with current sensing / * Standard version

Circuits

NO-Contact

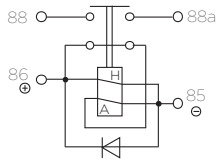

NO-Contact

Reversed polarity

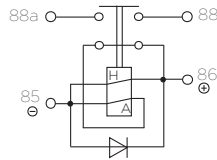

NO-Contact

with polarity protection

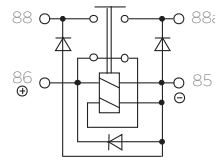

NO-Contact

with auxiliary contact

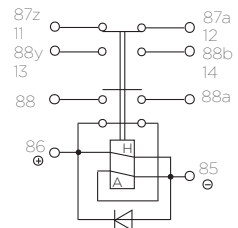

NC-Contact

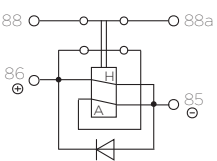

NC-Contact

with polarity protection

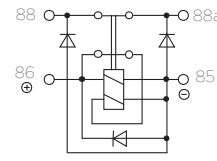

Accessories

Suppression diode

26.08.50

26.05.50.900
reverse polarity

Polarity protection

26.08.51

Angler adapter

26.08.52

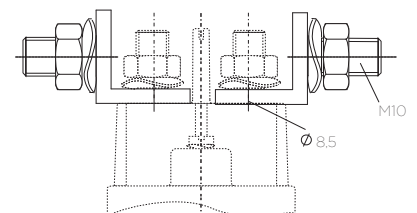
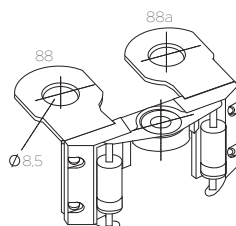
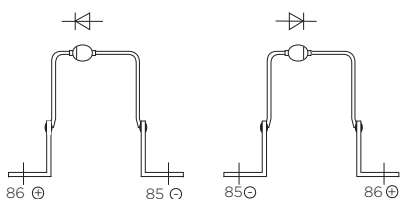

Technical drawings

Side mounting

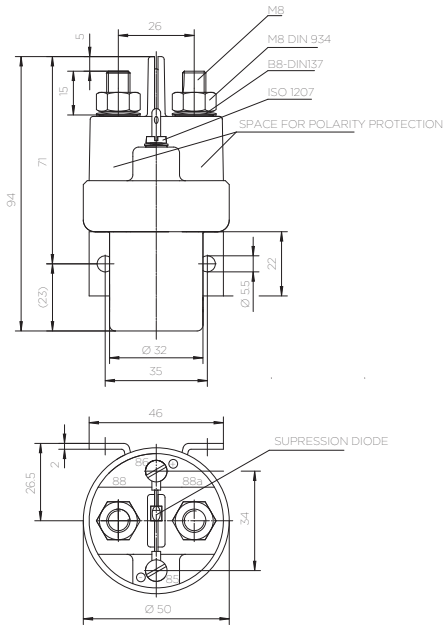

Side mounting with inserts

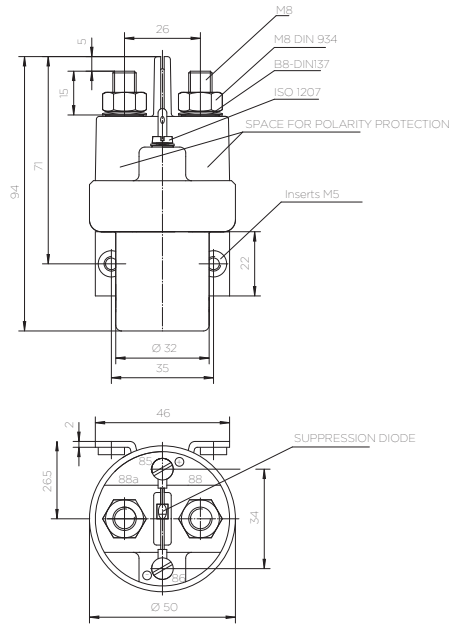

Side mounting - Auxiliary contact

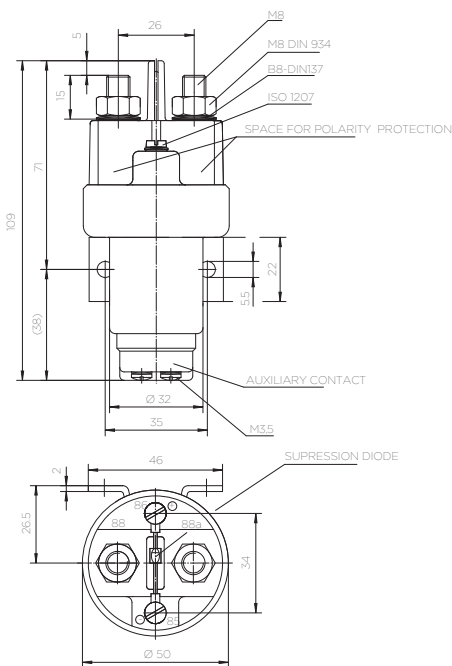

Side mounting - UNC Threads

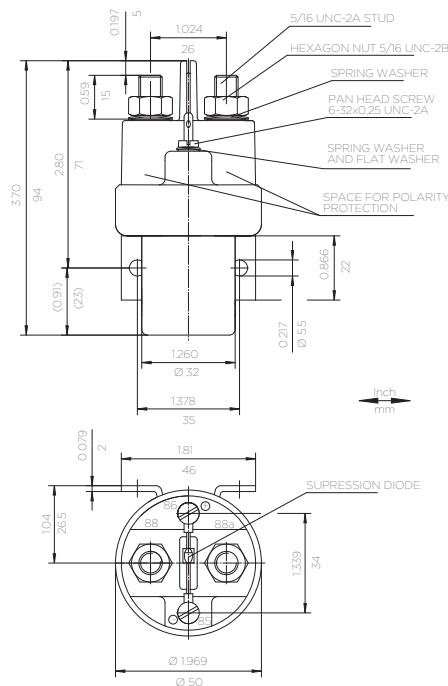

te.com

TE Connectivity, TE, TE connectivity (logo), KISSLING (logo) and KISSLING (word) are trademarks owned or licensed by the TE Connectivity family of companies. All other logos, products and/or company names referred to herein might be trademarks of their respective owners.

The information given herein, including drawings, illustrations and schematics which are intended for illustration purposes only, is believed to be reliable. However, TE Connectivity makes no warranties as to its accuracy or completeness and disclaims any liability in connection with its use. TE Connectivity's obligations shall only be as set forth in TE Connectivity's Standard Terms and Conditions of Sale for this product and in no case will TE Connectivity be liable for any incidental, indirect or consequential damages arising out of the sale, resale, use or misuse of the product. Users of TE Connectivity products should make their own evaluation to determine the suitability of each such product for the specific application.